

Fine Point Chuck / FP-50,51

For small to medium wire



[How to use it?]

This can be used to test tension strength for variety of materials.

[Feature]

This can be used for small to medium gauge wire.

It is suitable for low weight test because this attachment is lightweight model.

Use these for narrow space test.

[Specification]

	FP-51	FP-50
Type	Lightweight type	Normal
Capacity	50N	100N
Mounting Screws [S]	M6P1	M6P1
Measurement(WxDxH)	10x55x8 mm	10x55x8 mm
Open Range (A)	0.5mm	0.5mm
Weight	8 g	19 g
With Force Gauge	PS/FB/DPS/DPX 2.4N~50N	PSH/DPSH/DPXH 2.4N~100N

[Dimension]

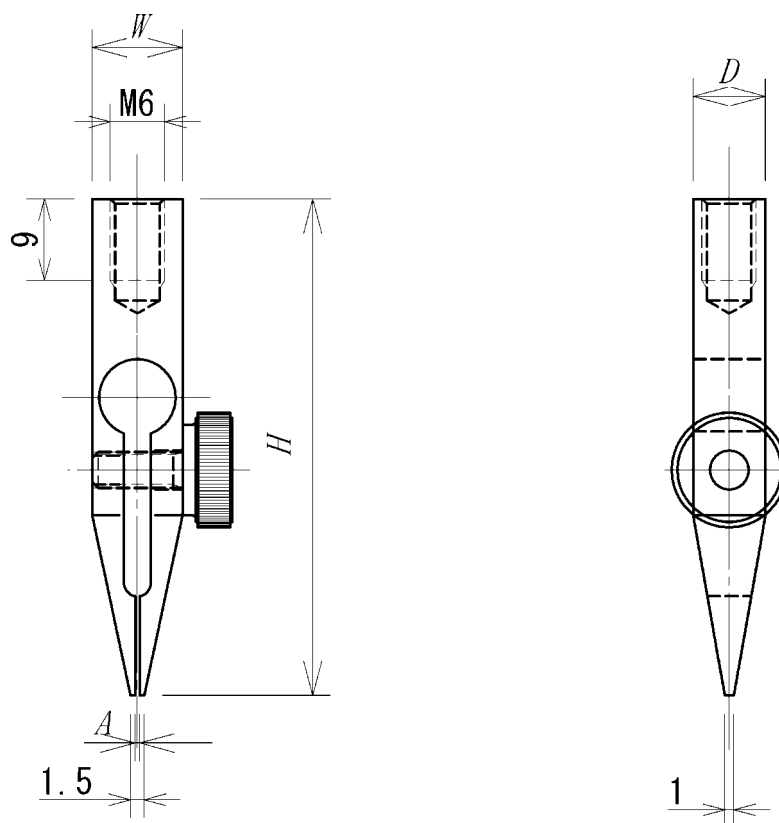

[Notes]

*Particular materials and shape can not be used.
 For stability test, we recommend our test stands.
 Design, appearance and specifications may be changed for modifications or improvements without any prior notice.*