

Hook for corrugated cardboard seal strength / DF-60

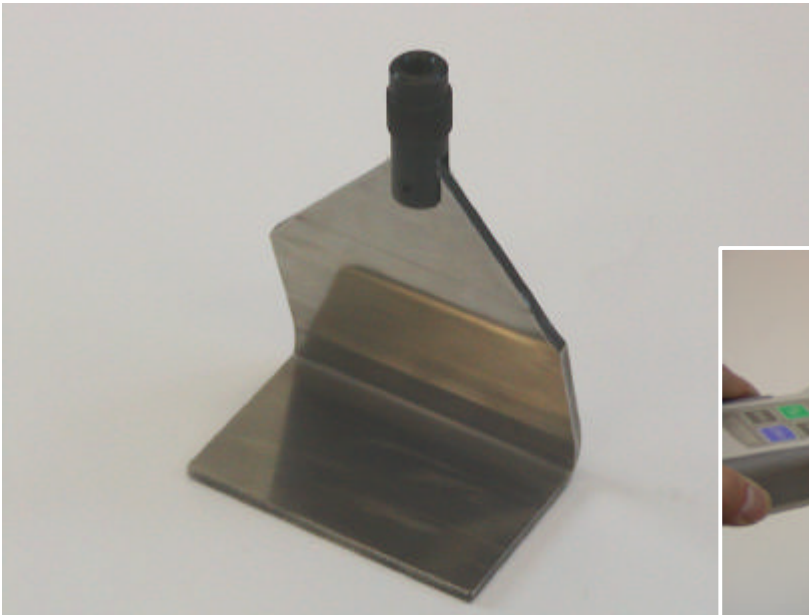

[Applications]

Suitable for the opening strength measurement of glued corrugated cardboard.  
Inspection for safe and sure shipment.  
The strength measurement for re-packing.

[Dimensions]

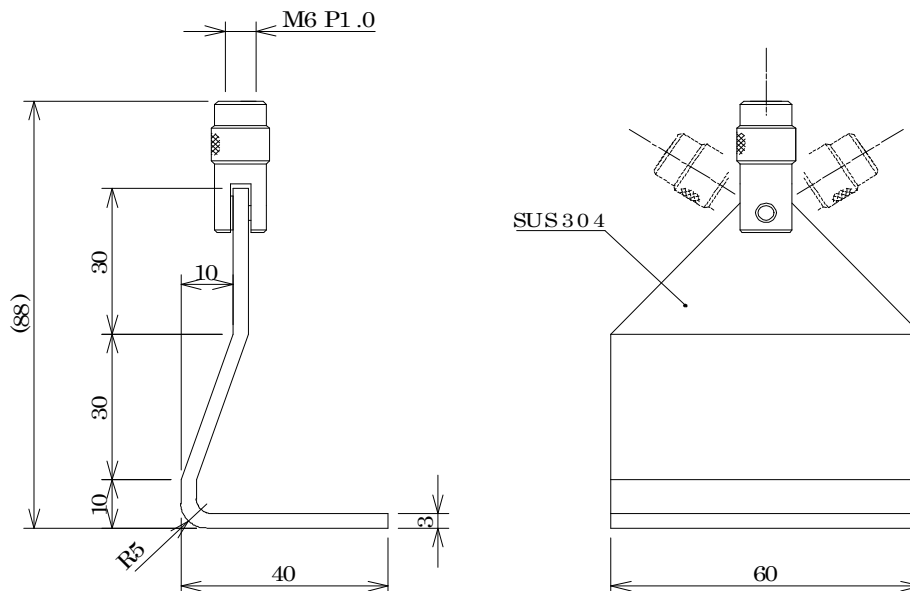

[Specifications]

Capacity / 250N  
Weight / Approx. 145g

[NOTICE]

All information is subject to change without prior notice!