

---

## Jacob's Chucks / GC-5,15

Ideal for measuring tensile strength of shafts or rods



GC-5

### [Application]

The Jacob's chuck is installed on the Imada's force gauge for pull or compression test of shafts and rods.

### [Feature]

The Jacob's chuck has characteristic of better initial gripping and less slipping of test material on testing process.

The secure chucking of test material is achieved by the attached tightening handle.

## [Specifications]

	GC-5	GC-15
Clamping stroke	Diameter 0.5 to 6.5 mm	Diameter 2.0 to 13 mm
Capacity	500N	1000N
Mounting screw	M6 P1	M6 P1 Note 1)
Dimension	Refer to the dimensional drawing below.	
Weight	Approx. 235 g	Approx. 500 g
Attachment	Tightening handle×1	
The recommended force gauge	PS/FB/DPS/DPX/DPZ series 29.4N to 500N	PS/FB/DPS/DPX/DPZ series 49N to 1000N

## Note 1)

Mounting screw hole can be modified to M10 for higher capacity force gauges, PSH/DPSH/DPXH/DPZH series (where capacity is up to 1000N). Please inform Imada of your requirement.

## [Dimensional drawing]

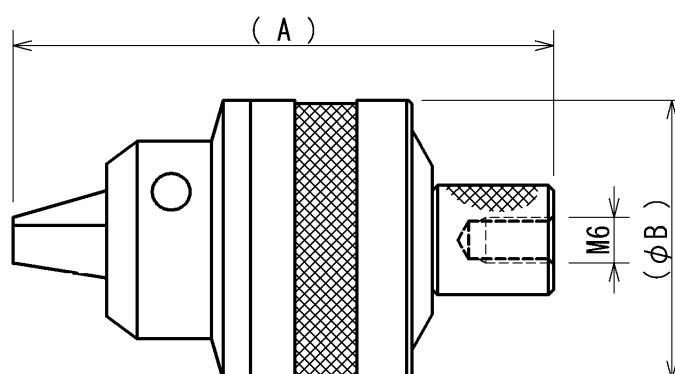

Model	( A )mm	( diameter B )mm	Screw hole
GC-5	72	37	M6 depth 9
GC-15	101	45	

## [Precautions]

- The Jacob's chuck can not grip particular material or shape.
- Combining with Imada's test stand, more stable measuring becomes possible.
- All information is subject to change without prior notice.