

Attachment for QFP lead 45 degree pull test : QFP45-100N

Attachment for TIP90 degree shear test : TIP90 -100N



1) TIP 90 degree shear test



2)QFP 45 degree pull test

[Applications]

- QFP lead 45 degree pull test
- TIP90 degree shear test

[Feature]

- Very small positioning is possible by precise X-Y stage
- Easy to fix PC board by breadboard.

## [Model]

Model	<b>QFP lead 45 degree pull test set / QFP45-100N</b> QFP45-1 : Hook attachment QFP45-2 : Table for 45 degree QFP-1 : X-Y stage
	<b>TIP 90 degree shear test set / TIP90-100N</b> TIP90-1 : Shear attachment TIP90-2 : Table for 90 degree QFP-1 : X-Y stage
	<b>Combination of QFP45 and TIP90 / LF</b> QFP45-1 : Hook attachment QFP45-2 : Table for 45 degree TIP90-1 : Shear attachment TIP90-2 : Table for 90 degree QFP-1 : X-Y stage
	<b>QFP and TIP measuring unit / MX-500NEOL550-LF-***N</b> QFP45-1 : Hook attachment QFP45-2 : Table for 45 degree TIP90-1 : Shear attachment TIP90-2 : Table for 90 degree QFP-1 : X-Y stage MX-500N-E-O-L550 : Motorized test stand Z series : Digital force gauge ***N (please choose the capacity)

## [Specifications]

Table dimension	200x150
Fix holes	M3P0.5x80    Minimum 20x20    Maximum 180x140
XY stage	Stroke : +/- 12.5mm    Resolution : 0.01mm
Dimension	See next page
Weight	QFP45-1 : Approx.60g QFP45-2 : Approx.650g TIP90-1 : Approx.50g TIP90-2 : Approx.650g QFP-1 : Approx.2.6kg

\* It is possible to supply customized tip and table for special size as optional.

[Dimension for TIP]

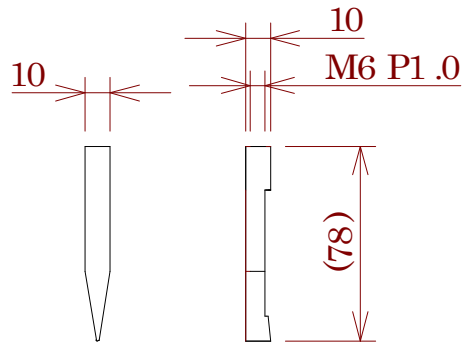

TIP90-1

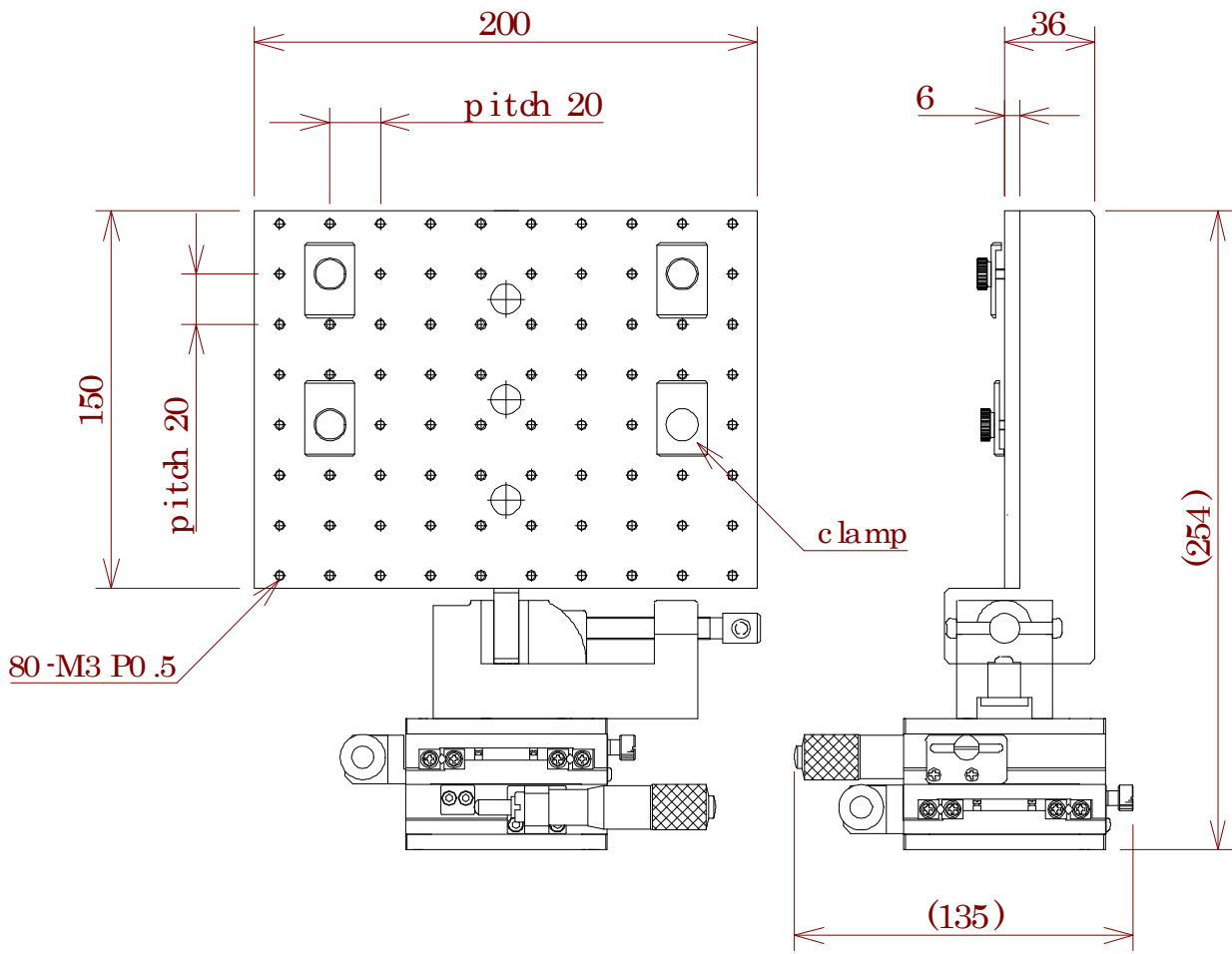

TIP90-2 + QFP-1

[Dimension for QFP]

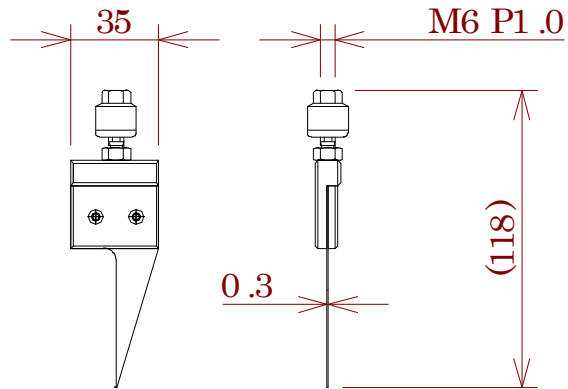

QFP45-1

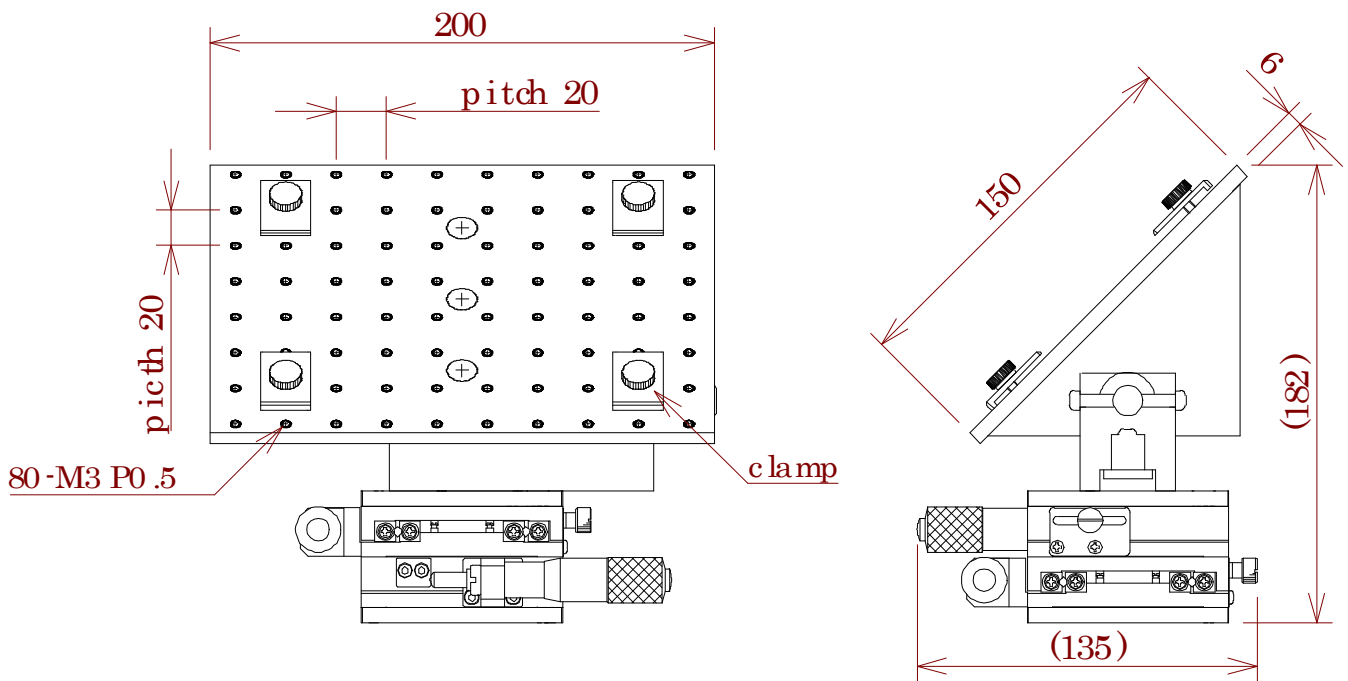

QFP45-2 + QFP-1

[Precaution]

- Combining with Imada's test stand, more stable measuring becomes possible.
- All information is subject to change without prior notice.